



INSTRUCTION MANUAL

HF/50 MHz ALL BAND
1 kW LINEAR AMPLIFIER

IC-PW1 IC-PW1EURO



IMPORTANT

READ THIS INSTRUCTION MANUAL CAREFULLY before attempting to operate the linear amplifier.

SAVE THIS INSTRUCTION MANUAL. This instruction manual contains important safety and operating instructions for the IC-PW1/IC-PW1EURO.

PRECAUTION

⚠ WARNING HIGH VOLTAGE! NEVER attach an antenna or internal antenna connector during transmission. This may result in an electrical shock or burn.

⚠ WARNING! NEVER carry the linear amplifier by yourself. At least two persons must carry the linear amplifier since it weighs approx. 25 kg (55 lb).

⚠ WARNING! NEVER apply AC voltage until the linear amplifier is grounded. Touching the linear amplifier may result in an electrical shock.

⚠ NEVER apply AC voltage that exceeds the suggested voltage. This could cause a fire or ruin the IC-PW1/EURO.

⚠ NEVER use an extension cord with the AC power cable. Extension cords may cause fire or electrical shock.

⚠ NEVER let metal, wire or other objects touch any internal part or connectors on the panel of the linear amplifier. This will cause electric shock.

⚠ NEVER expose the linear amplifier or remote controller to rain, snow or any liquids.

NEVER allow children to play with the linear amplifier or remote controller.

DO NOT operate the IC-PW1/EURO before adjusting the [ALC adj1] and [ALC adj2] pots properly on the rear panel of the linear amplifier.

AVOID using or placing the linear amplifier or remote controller in areas with temperatures below -10°C ($+14^{\circ}\text{F}$) or above $+40^{\circ}\text{C}$ ($+104^{\circ}\text{F}$).

AVOID placing the linear amplifier or remote controller in excessively dusty environments or in direct sunlight.

AVOID placing the linear amplifier against walls or putting anything on top of the linear amplifier. This will obstruct heat dissipation.

BE CAREFUL! The linear amplifier will become hot when operating if continuously for long periods.

BE CAREFUL! Set the transceiver's (exciter's) RF output power to less than 100 W, otherwise, the IC-PW1/EURO will be damaged.

During maritime mobile operation, keep the linear amplifier, remote controller and microphone as far away as possible from the magnetic navigation compass to prevent erroneous indications.

The IC-PW1/EURO cannot be used with the AH-2 HF AUTOMATIC ANTENNA TUNER.

For U.S.A. only

CAUTION: Changes or modifications to this device, not expressly approved by Icom Inc., could void your authority to operate this device under FCC regulations.

EXPLICIT DEFINITIONS

WORD	DEFINITION
⚠ WARNING	Personal injury, fire hazard or electric shock may occur.
CAUTION	Equipment damage may occur.
NOTE	If disregarded, inconvenience only. No risk of personal injury, fire or electric shock.

The explicit definitions described at left apply to this instruction manual.

TABLE OF CONTENTS

IMPORTANT	i	■ System interconnections	7
PRECAUTION	i	■ Separating the remote controller	11
EXPLICIT DEFINITIONS	ii	3 OPERATION	12–17
TABLE OF CONTENTS	ii	■ When first applying power (CPU resetting) ...	12
SUPPLIED ACCESSORIES	ii	■ Setting the ALC levels	12
		■ Programming the CI-V address	13
1 PANEL DESCRIPTION	1–4	■ Initial settings for CI-V remote control operation	14
■ Front panel and remote controller	1	■ Operation	16
■ Rear panel	3	■ Antenna tuner operation	17
2 INSTALLATION AND CONNECTIONS	5–10	■ Protection circuit	17
■ Unpacking	5	4 MAINTENANCE	18
■ Ferrite core installation	5	■ Troubleshooting	18
■ OPC-853 AC cable with line filter	5	5 SPECIFICATIONS	19
■ Selecting a location	5	ABOUT CE	20
■ AC power cable connection	5		
■ Grounding	6		
■ Antenna	6		

SUPPLIED ACCESSORIES

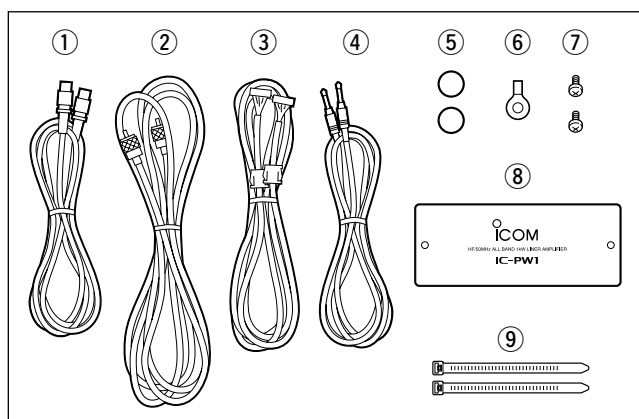

Accessories included with the IC-PW1/EURO: Qty.

①	Accessory cable (OPC-104B)	1
②	Coaxial cable (OPC-125B)	1
③	Separation cable (OPC-730)	1
④	Remote control (CI-V) cable (OPC-718)	1
⑤	Remote controller feet	2
⑥	Grounding lug	1
⑦	Dummy panel screws	2
⑧	Dummy panel	1
⑨	Cable ties	2

1

PANEL DESCRIPTION

■ Front panel and remote controller

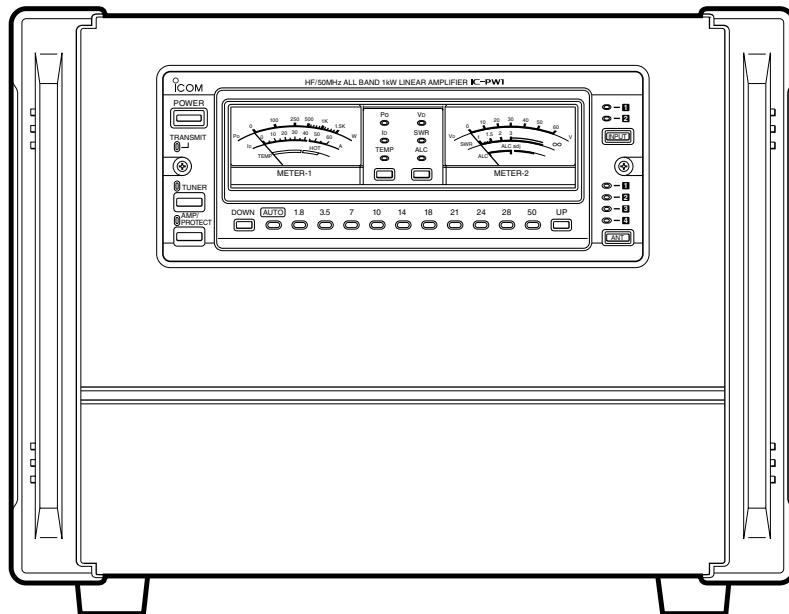
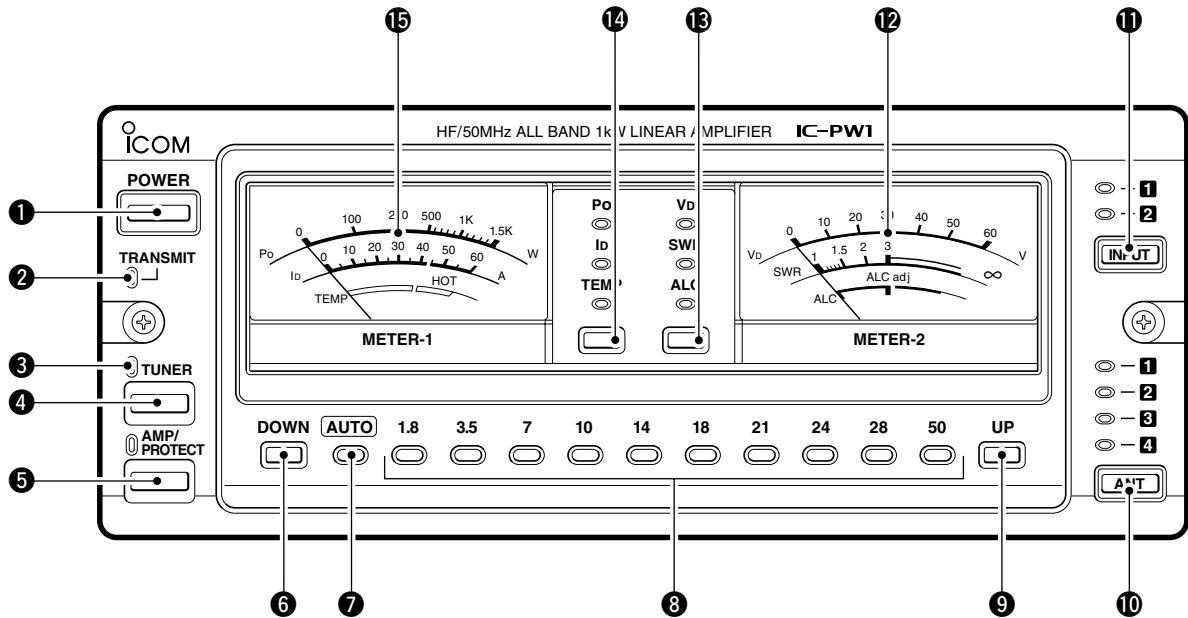

1 POWER SWITCH [POWER] (p. 12)

Push momentarily to turn power ON.

2 TRANSMIT INDICATOR [TRANSMIT] (p. 16)

Lights green while transmitting.

During transmission, a humming may sound depending on the output power. This is caused by the large current produced by the power supply and does not indicate equipment malfunction.

3 ANTENNA TUNER INDICATOR [TUNER] (p. 16)

- Lights while the antenna tuner is activated.
- Blinks while tuning and the SWR becomes 1.5:1 or greater on the 50 MHz band.
- Goes out after slow blinking when antenna tuner cannot tune the selected antenna (SWR 1.5:1 or greater).

4 ANTENNA TUNER SWITCH [TUNER] (p. 17)

- Turns the antenna tuner ON and OFF (bypass) when pushed momentarily.
 - The [TUNER] indicator lights while the antenna tuner is activated; blinks while tuning.
 - While operating in the 50 MHz band, the antenna tuner does not start automatically. Push [TUNER] for 2 sec. to tune the antenna manually.
- Starts to tune the antenna manually when pushed for 2 sec.
 - When the tuner cannot tune the antenna (SWR 1.5:1 or greater), the tuning circuit is bypassed automatically after 20 sec.

5 LINEAR AMPLIFIER SWITCH [AMP/PROTECT]

Turns the linear amplifier ON and OFF.

- The [AMP/PROTECT] indicator lights green when the linear amplifier is ON. (p. 16)
- The [AMP/PROTECT] indicator lights red when the protector circuit is activated. (p. 17)
- When the linear amplifier is OFF, the [AMP/PROTECT] does not light and the exciter's signal is applied to one of the output connectors or the IC-PW1/EURO's antenna tuner.

6 LOWER BAND SELECTOR [DOWN] (p. 16)

Selects the lower operating band when pushed.

7 AUTOMATIC INDICATOR [AUTO] (p. 16)

Indicates that automatic band selection is activated. (When an Icom CI-V transceiver is connected.)

8 BAND INDICATORS (p. 16)

Indicate the selected operating band.

9 UPPER BAND SELECTOR [UP] (p. 16)

Selects the higher operating band when pushed.

10 OUTPUT ANTENNA SELECTOR [ANT] (p. 16)

Selects one of 4 output antenna connectors.

11 INPUT ANTENNA SELECTOR [INPUT] (p. 16)

Selects one of 2 input antenna connectors.

12 TRANSMIT METER-2 [METER-2]

Shows the final FET's voltage (V_D), SWR (Standing Wave Ratio) or ALC (Automatic Level Control) level.

13 TRANSMIT METER-2 SELECTOR

Selects the final FET's voltage (V_D), SWR (Standing Wave Ratio) or ALC (Automatic Level Control) level for transmit meter-2.

14 TRANSMIT METER-1 SELECTOR

Selects the RF output power (P_o), final FET's current (I_D) or heatsink temperature (TEMP) for transmit meter-1.

15 TRANSMIT METER-1 [METER-1]

Shows the RF output power (P_o), final FET's current (I_D) or heatsink temperature (TEMP).

■ Rear panel

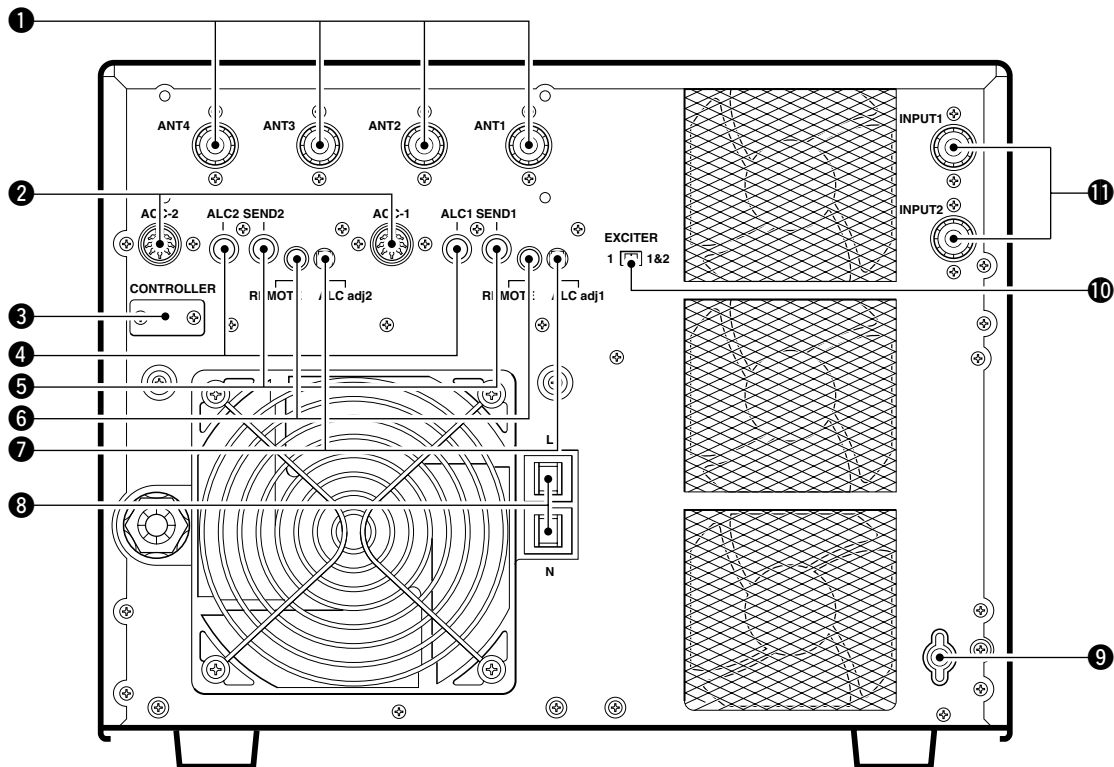

1 OUTPUT ANTENNA CONNECTORS

[ANT1] – [ANT4] (p. 6)
Accept a 50 Ω antenna with a PL-259 connector.

**2 ACCESSORY SOCKET-1 [ACC-1]
ACCESSORY SOCKET-2 [ACC-2]**

Enable connection to Icom excitors (transceivers).
- See the page at right for socket information.
- The [ACC-2] socket is connected in parallel with [ACC-1] by default and can be used for connecting external equipment such as the EX-627 AUTOMATIC ANTENNA SELECTOR, etc. These sockets can be separated by the [EXCITER] switch. (10)

3 REMOTE CONTROLLER CABLE HOLE [CONTROLLER] (p. 11)

Used for separation of the remote controller and linear amplifier.

4 ALC OUTPUT JACKS [ALC1]/[ALC2] (p. 12)

Connect to the ALC input jack of a non-Icom exciter (transceiver).
- Control voltage: -10 to 0 V DC

5 SEND CONTROL JACKS [SEND1]/[SEND2]

(p. 9)
Input terminals for transmit control. Go to ground while transmitting.
- Max. control level: 5.0 V DC/0.1 A
- Ground level: -0.5 to 0.8 V DC

6 CI-V REMOTE CONTROL JACKS [REMOTE]

(pgs. 7–9)
Used for band control with an Icom CI-V exciter (transceiver).

7 ALC LEVEL ADJUSTMENT POTS [ALC adj1]/[ALC adj2]

(p. 12)
Adjust the ALC levels.

⚠ CAUTION! DO NOT operate the IC-PW1/EURO before adjusting the [ALC adj1] and [ALC adj2] pots properly. This may damage the final FETs.

8 CIRCUIT BREAKERS (p. 17)

Cut off the AC input when over current occurs.
- Circuit breaker capacity: 20 A (U.S.A. version)
15 A (Europe version)

9 GROUND TERMINAL (p. 6)

Connect this terminal to a ground to prevent electrical shocks, TVI, BCI and other problems.

⑩ **EXCITER SELECTOR [EXCITER]** (pgs. 7–9)

- Sets the connected exciter number.
- Select [1] when 1 exciter is connected. [ACC-2] outputs the received [ACC-1] signal to another Icom option such as the EX-627 AUTOMATIC ANTENNA SELECTOR.
 - Select [1&2] when 2 exciters or 1 exciter with 2 specified band antenna connectors is connected.

⑪ **INPUT ANTENNA CONNECTORS**
[INPUT1]/[INPUT2] (p. 6)

Accept a 50 Ω antenna with a PL-259 connector.

◇ **ACC-1 SOCKET**

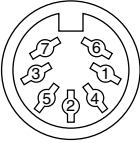
ACC-1	PIN NO.	PIN NAME	DESCRIPTION	SPECIFICATIONS
 <p>Rear panel view</p>	1	8 V	Regulated reference 8 V DC input for band control.	Input voltage : 8 V ±0.3 V Input current : Less than 10 mA
	2	GND	Connects to ground.	
	3	SEND	Input/output pin. Goes to ground when transmitting. When grounded, transmits.	Ground level : -0.5 V to 0.8 V Output current : Less than 20 mA Input current : Less than 200 mA
	4	BAND	Band voltage input. (Varies with amateur band)	Input voltage : 0 to 8.0 V
	5	ALC	ALC voltage output.	Control voltage : -10 to 0 V Output impedance : 10 kΩ
	6	NC	No connection.	
	7	13.8 V	13.8 V DC input terminal.	Input current : Less than 1 A

◇ **ACC-2 SOCKET** (w/[EXCITER] is "1")

/// The following descriptions are applied when the [EXCITER] switch is set to "1" (default). When [EXCITER] is set to "1&2," [ACC-2] functions the same as [ACC-1] above for the 2nd exciter.

ACC-2	PIN NO.	PIN NAME	DESCRIPTION	SPECIFICATIONS
 <p>Rear panel view</p>	1	8 V	Regulated reference 8 V DC output from the [ACC-1] socket.	Output voltage : 8 V ±0.3 V Output current : Less than 10 mA
	2	GND	Connects to ground.	
	3	SEND	Input/output pin. Goes to ground when transmitting. When grounded, transmits.	Ground level : -0.5 V to 0.8 V Output current : Less than 20 mA Input current : Less than 200 mA
	4	BAND	Band voltage output from the [ACC-1] socket. (Varies with amateur band)	Output voltage : 0 to 8.0 V
	5	ALC	ALC voltage output.	Control voltage : -10 to 0 V Output impedance : 10 kΩ
	6	NC	No connection.	
	7	13.8 V	13.8 V DC output terminal from the [ACC-1] socket.	Output current : Less than 1 A

■ Unpacking

After unpacking, immediately report any damage to the delivering carrier or dealer. Keep the shipping cartons.

For a description and a diagram of accessory equipment included with the IC-PW1/EURO, see SUPPLIED ACCESSORIES on p. ii of this manual.

■ Ferrite core installation

The supplied cable ties (⑨ in SUPPLIED ACCESSORIES) should be attached to the AC cable of the IC-PW1/EURO as illustrated below.

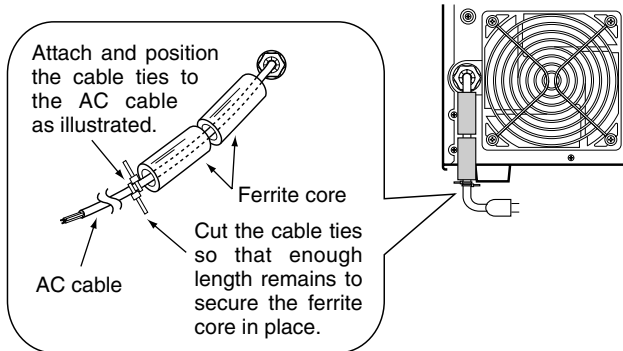

NOTE: Only one ferrite core is attached with the IC-PW1EURO.

■ OPC-853 AC cable with line filter

The IC-PW1EURO must be used with the OPC-853 AC cable to satisfy European R&TTE requirements.

■ Selecting a location

Select a location for the linear amplifier that allows adequate air circulation, free from extreme heat, cold, or vibrations, and away from TV sets, TV antenna elements, radios and other electro-magnetic sources.

The linear amplifier and remote controller sections of the IC-PW1/EURO can be separated. The remote controller can be placed near the operator for easy monitoring of linear amplifier conditions at any time. See p. 10 for separation instructions.

The linear amplifier must be placed on a solid foundation since it is very heavy.

■ AC power cable connection

A suitable AC power plug must be connected to the AC power cable end. See the diagram below for connection procedures. AC input voltage is automatically selected.

The IC-PW1/EURO can accept either 100–120 V AC or 200–240 V AC power.* However, we recommend using 200–240 V AC rather than 100–120 V AC for better power supply efficiency and longer periods of transmission.

* Europe version: 230 V AC only

◆ Single-phase 3-wire line (200–240 V AC)

- ① The green wire from the AC power cable must be connected to the protective earth.
- ② The black and white wires from the AC power cable can be connected to either terminal.

※ *Use the appropriate AC plug if required.

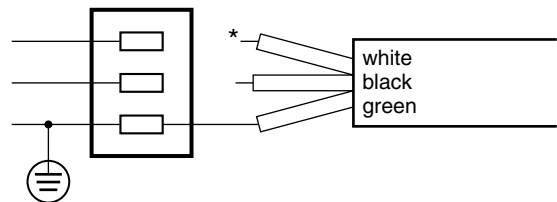

◆ Single-phase 2-wire line (100–120 V AC)

- ① The green wire from the AC power cable must be connected to the protective earth.
- ② The black wire from the AC power cable must be connected to the hot (live) wire.
- ③ The white wire from the AC power cable must be connected to the return wire.

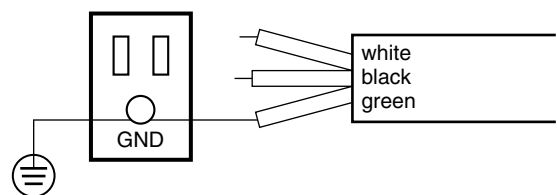

◆ Three-phase 3-wire line (200–240 V AC)

- ① The green wire from the AC power cable must be connected to the protective earth.
- ② The black and white wires from the AC power cable can be connected to 2 of 3 wires.

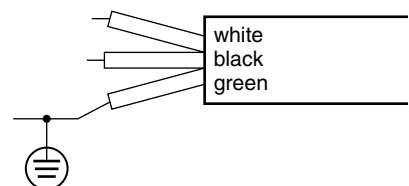

■ Grounding

To prevent electrical shock, television interference (TVI), broadcast interference (BCI) and other problems, ground the linear amplifier through the GROUND terminal on the rear panel.

For best results, connect a heavy gauge wire or strap to a long earth-sunk copper rod. Make the distance between the GROUND terminal and ground as short as possible.

⚠ WARNING: NEVER connect the GROUND terminal to a gas or electric pipe, since the connection could cause an explosion or electric shock.

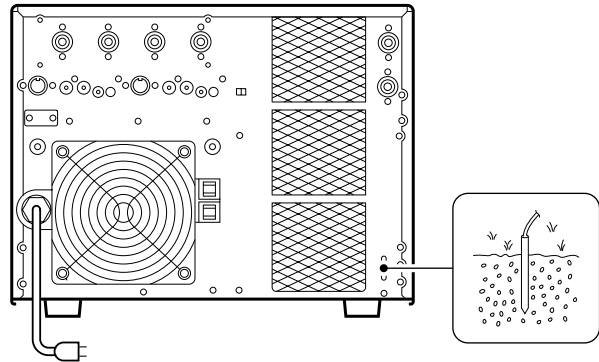

■ Antenna

For radio communications, the antenna is of critical importance, along with output power and sensitivity. Select antenna(s), such as a well-matched 50 Ω antenna with more than 2 kW power rating, and feed-line. 1.5:1 of Voltage Standing Wave Ratio (VSWR) is recommended for a desired band. Of course, the transmission line should be a coaxial cable.

When using 1 antenna, use the [ANT1] connector.

⚠ CAUTION: Protect your linear amplifier from lightning by using a lightning arrestor.

Antenna SWR

Each antenna is tuned for a specified frequency range and SWR may be increased out-of-range. When the SWR is higher than approx. 2.0:1, the linear amplifier's power drops to protect the final FET. In this case, an antenna tuner is useful to match the linear amplifier and antenna. Low SWR allows full power for transmitting even when using the antenna tuner. The IC-PW1/EURO has an SWR meter to monitor the antenna SWR continuously.

PL-259 CONNECTOR INSTALLATION

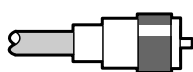
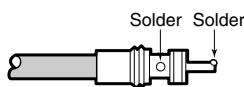
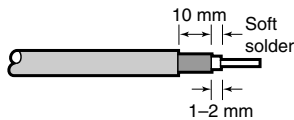
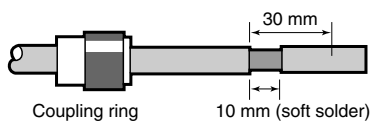

- ① Slide the coupling ring down. Strip the cable jacket and soft solder.
- ② Strip the cable as shown at left. Soft solder the center conductor.
- ③ Slide the connector body on and solder it.
- ④ Screw the coupling ring onto the connector body.

30 mm ≈ 9/8 in 10 mm ≈ 3/8 in 1-2 mm ≈ 1/16 in

■ System interconnections

1 or 2 Icom 100 W HF transceivers can be connected as exciters to the IC-PW1/EURO. Non-Icom transceivers can be used, however, band selection will not be synchronized for each exciter.

See the following diagrams for making connections between the IC-PW1/EURO and an exciter (transceiver). See p. 5 for AC power cable connection.

CAUTION!: When connecting the supplied ACC cable to an Icom transceiver, **be sure to connect the cable to the 7-pin [ACC(2)] jack on the exciter (transceiver) side.**

If the ACC cable is connected to the 8-pin [ACC(1)] jack, the protector circuit in the IC-PW1/EURO will not be able to read the ALC signal. If operation continues using this setup, damage (including the possibility of explosion) to the connected transceiver and/or IC-PW1/EURO will occur.

Icom standard 8 and 7-pin accessory jacks (transceiver side)

[ACC(1)]

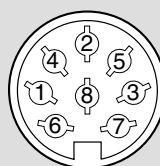

[ACC(2)]

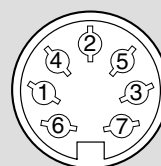

• Using 1 Icom exciter (transceiver)

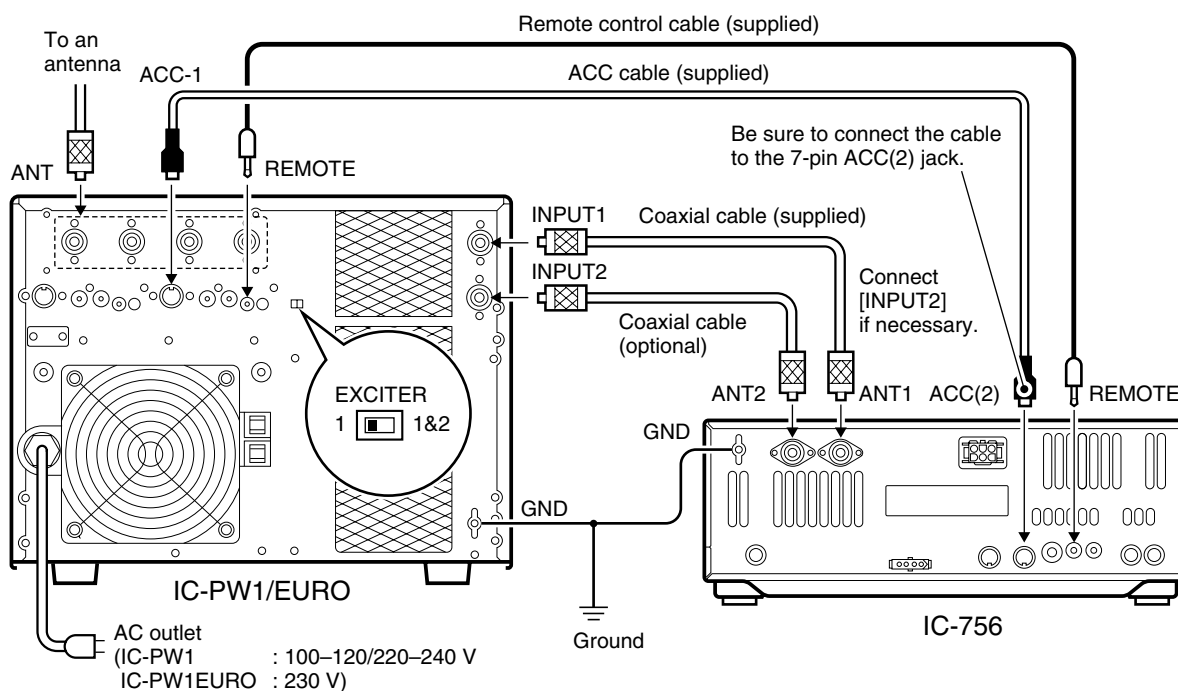

•Using a 13-pin ACC socket (IC-706 series)

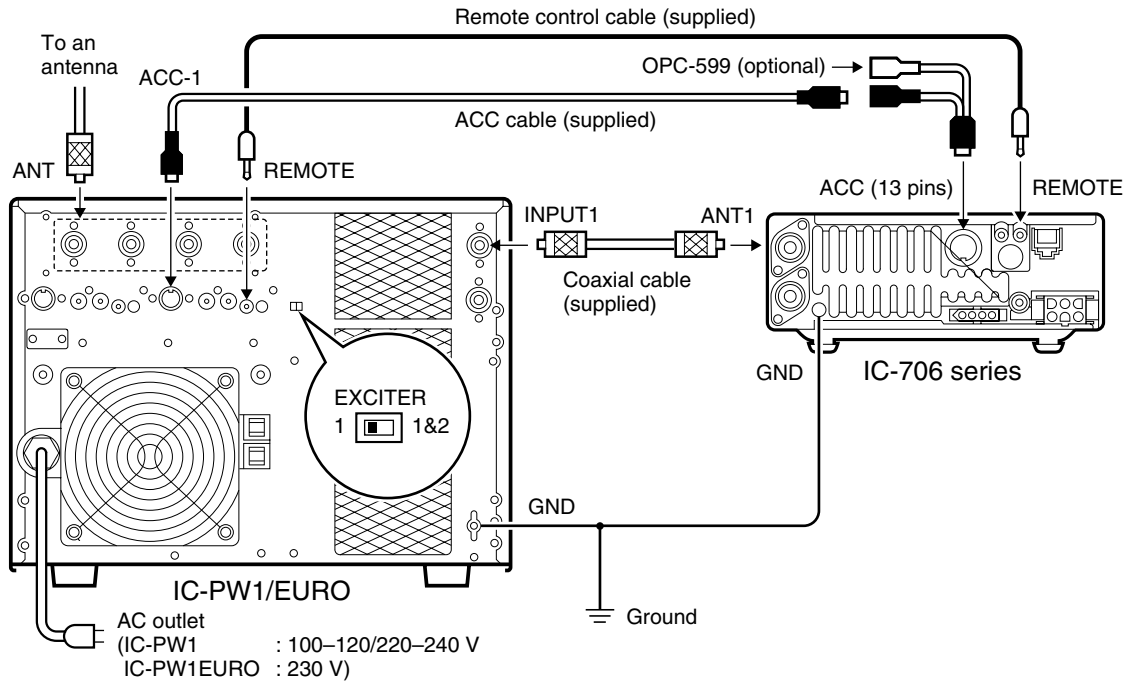

•Using 2 Icom exciters (transceivers)

▨ The following connections also apply to transceivers having multiple antenna connectors for specified bands (e.g. IC-726, IC-729, etc.)

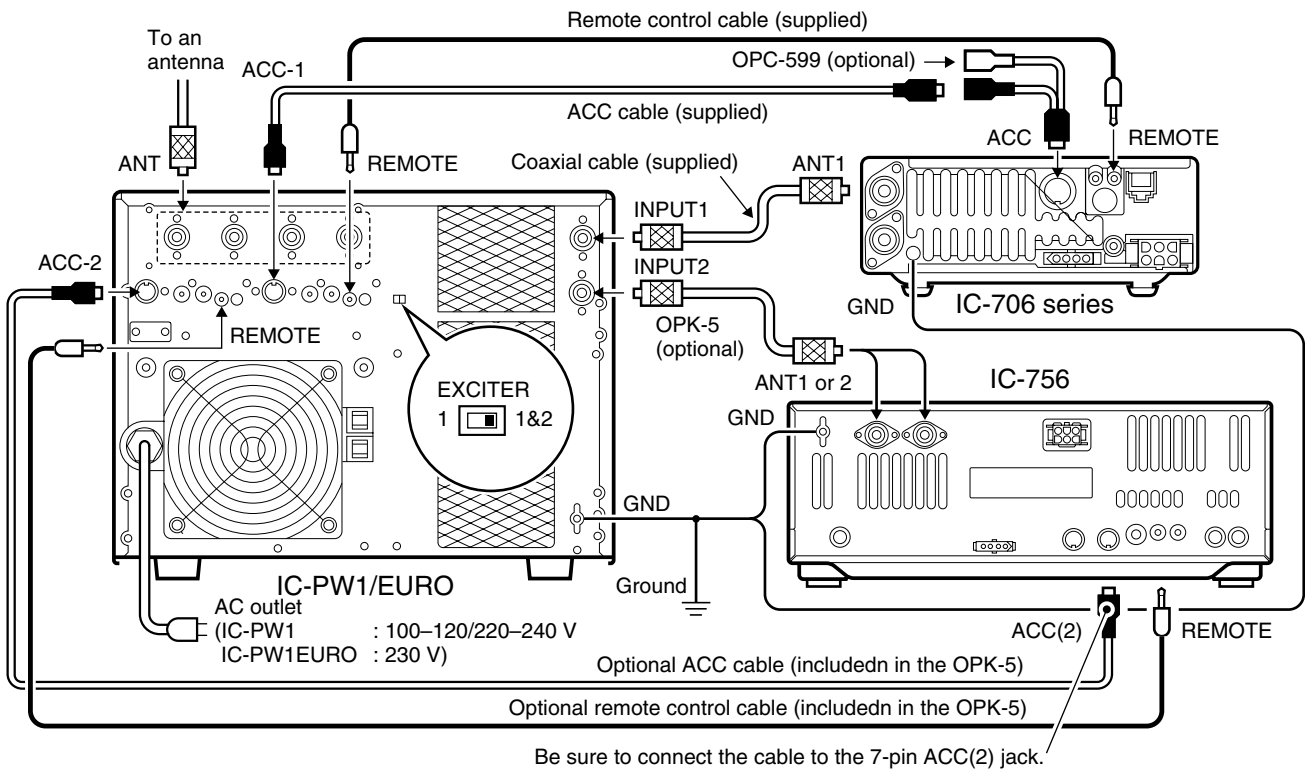

2 INSTALLATION AND CONNECTIONS

•Using a non-Icom exciter (transceiver)

Set the [EXCITER] switch to [1] when 1 exciter is connected; set to [1&2] when 2 exciters are connected.

NOTE: The specifications for the SEND relay are 5 V DC 0.1 A. If this level is exceeded, a large external relay must be used.

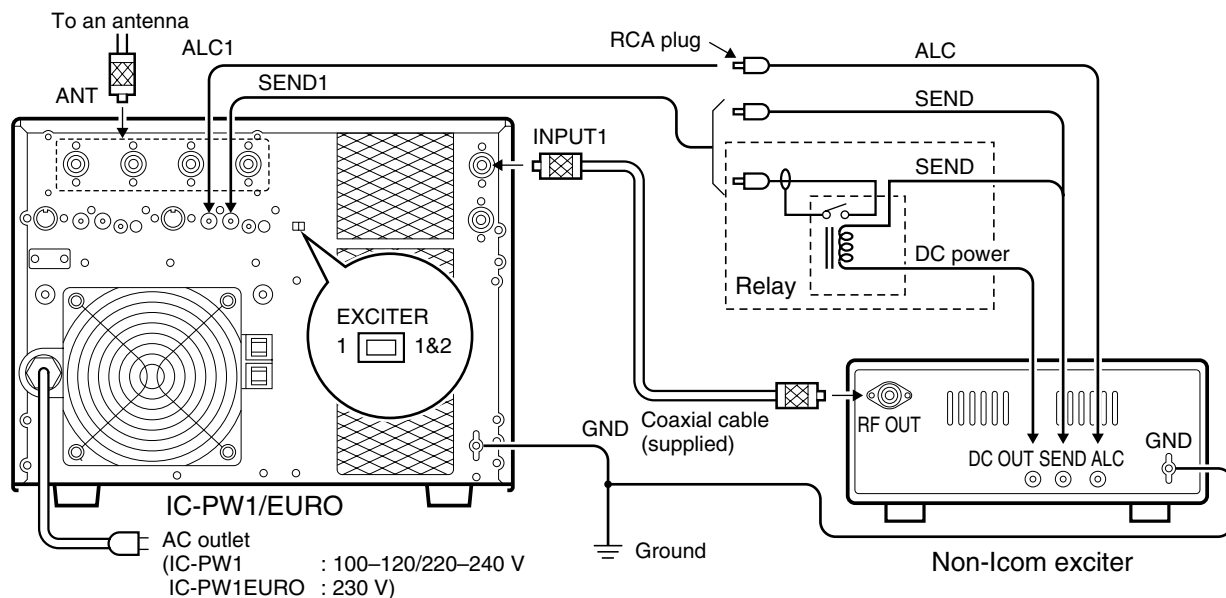

•Using 1 Icom and 1 non-Icom exciters (transceivers)

NOTE: The specifications for the SEND relay are 5 V DC 0.1 A. If this level is exceeded, a large external relay must be used.

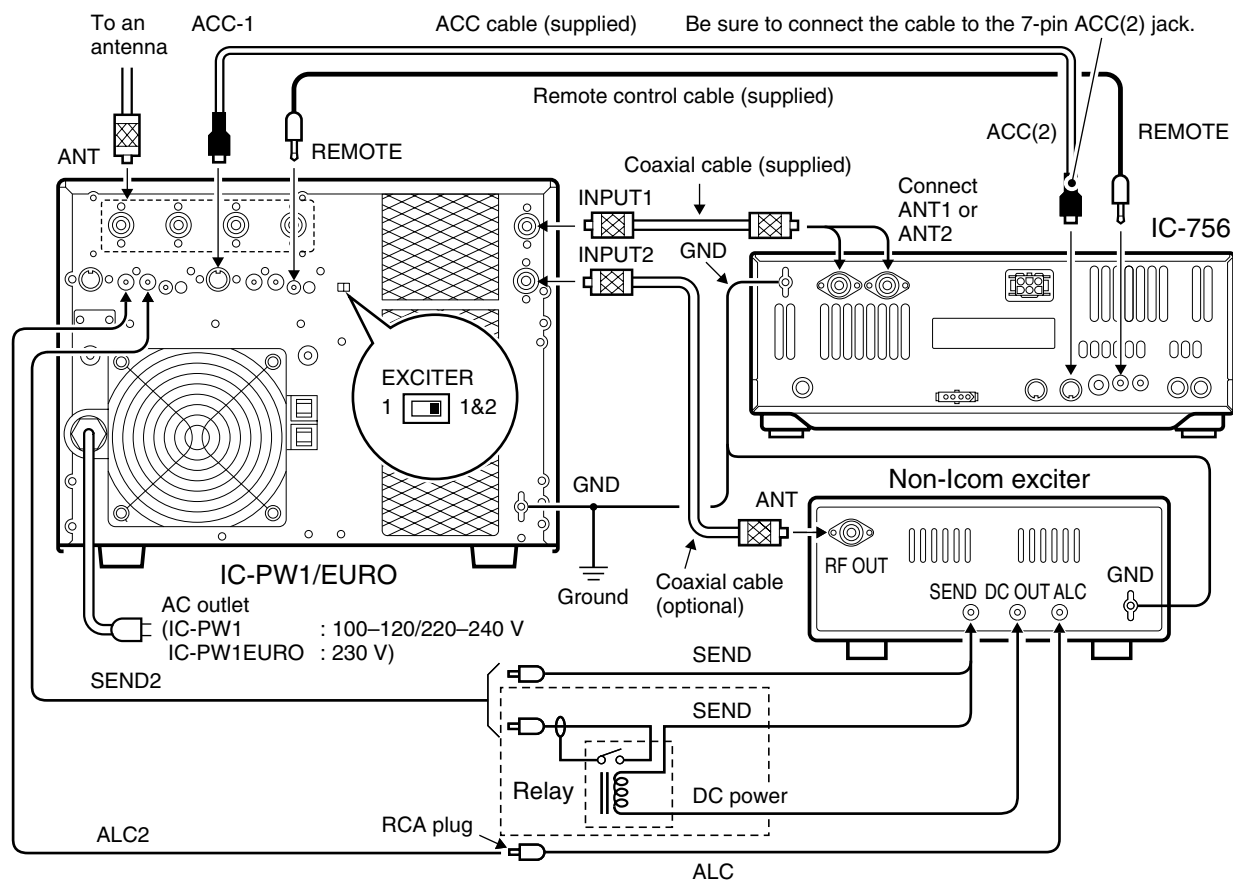

•Using non-Icom excitors (transceivers) when the IC-PW1/EURO's power is OFF

To use the antenna selector of the IC-PW1/EURO while the power is OFF, follow 1 of 2 methods.

(1) Supply the antenna selector power to the ACC-1 socket

Supply the 13.8 V DC, 0.5 A to pin 7 of the [ACC-1]/[ACC-2] socket.

- Use [ACC-1] when the exciter is connected to [INPUT1].
- Use [ACC-2] when the exciter is connected to [INPUT2].

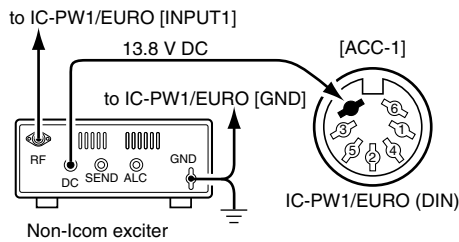

(2) Use the auxiliary power supply

Set the jumper to '2' to use the auxiliary power supply as shown at right.

- The antenna selector functions even when the IC-PW1/EURO power is OFF

In addition set the jumper on the IC-PW1/EURO controller to '2' to turn the controller's LEDs OFF as shown at right.

- ▨ When the jumper is set to '2,' the CI-V control does not function even if an Icom exciter is connected.

•Jumper location of linear amplifier

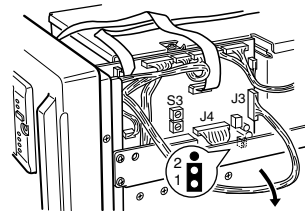

•Jumper location of controller

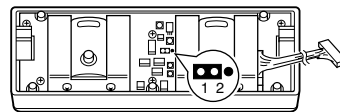

These diagrams show the factory defaults.

NOTE: When using the antenna selector of the IC-PW1/EURO while the power is OFF, as above, tuner initialization of the IC-PW1/EURO may not be performed correctly if the applied voltage is insufficient. Check that the applied voltage to pin 7 of [ACC-1]/[ACC-2] socket is 13.8 V DC.

■ Separating the remote controller

The control section of the linear amplifier can be separated from the main body, doubling as a remote controller. It can be placed on the exciter or in another convenient place.

- ① Disconnect the AC power cable.
- ② Remove 8 screws from the sides of the linear amplifier, then lift up the top cover.

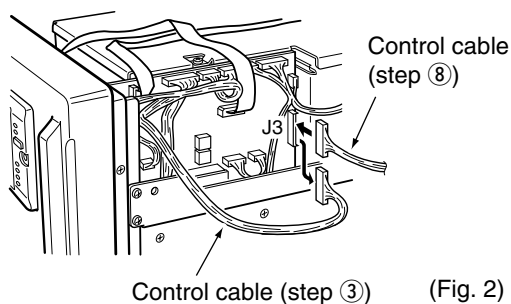
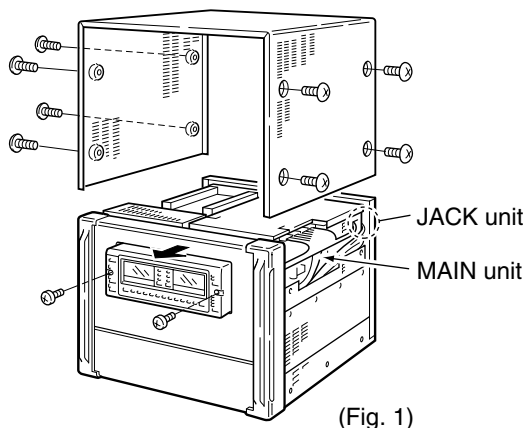

- ③ Unplug the control cable from J3 on the MAIN unit.
- ④ Remove 2 screws from the front panel of the linear amplifier, then detach the remote controller. (Fig. 1) Attach the dummy panel onto the space left by the controller using the 2 screws.

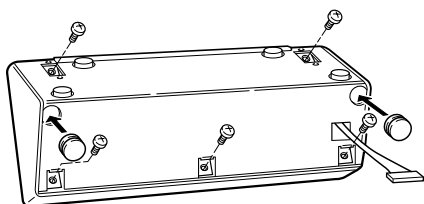

- ⑤ Remove 5 screws from the rear panel of the remote controller, then remove the rear panel.

- ⑥ Replace the control cable with the supplied separation cable through the cable hole. Use the shorter end (from the bushing) to connect to the remote controller.

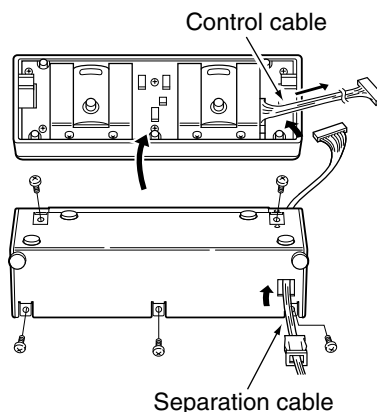

- ⑦ Remove 2 screws from the cable hole cover on the linear amplifier rear panel. Insert the separation cable into the cable hole. Keep the hole cover and screws for future use.

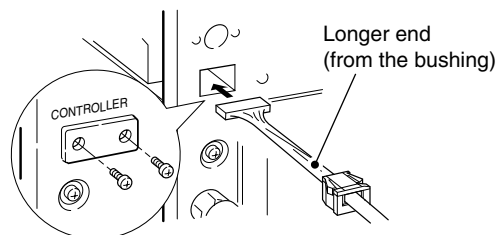

- ⑧ Plug the other longer end (from the bushing) of the separation cable into J10 on the JACK unit through the cable hole. Connect the grounding wire as shown below. Connect the control cable to J11.

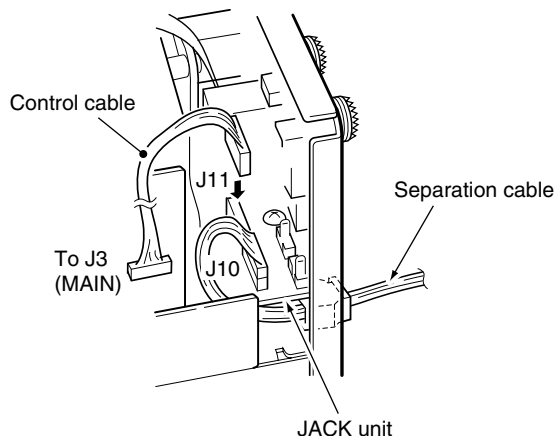

- ⑨ Plug the other end of the control cable into J3 on the MAIN unit. (Fig. 2)
- ⑩ Replace the top cover and 8 screws.

■ When first applying power (CPU resetting)

Before first applying power, make sure all connections required for your system are complete by referring to chapter 2. Then, reset the linear amplifier using the following procedure.

NOTE: Resetting CLEARS all programmed settings to default values.

- ① Make sure the linear amplifier, exciter and auxiliary power supply (p. 10) powers are OFF.
- ② While pushing [UP] and [DOWN], push [POWER] to turn power ON.
 - The internal CPU is reset.
 - The remote controller shows its initial condition when resetting is complete.
- ③ Reset the exciter's CI-V settings after resetting. (pgs. 13, 14)

If the controller's power is supplied from non-Icom exciters or auxiliary power supply (p. 10), turn the exciter or auxiliary power supply ON while pushing [UP] and [DOWN] to reset the CPU.

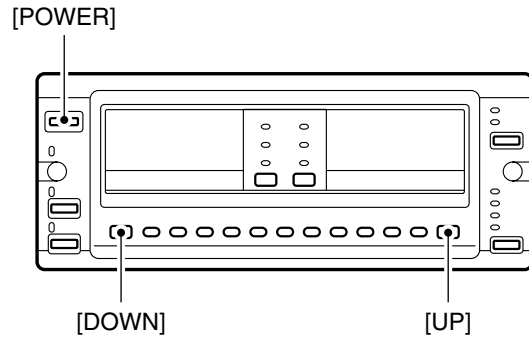

■ Setting the ALC levels

CAUTION: Final FETs may be damaged if the ALC level adjustment is set incorrectly.

NOTE: Re-adjustment is necessary when replacing the exciter.

- ① Select an antenna which has an SWR of 1.5:1 or better.
- ② Set the 1st exciter's RF output power for the minimum output.
- ③ Be sure that the [ALC adj1] and [ALC adj2] pots on the rear panel max. counterclockwise. (default)

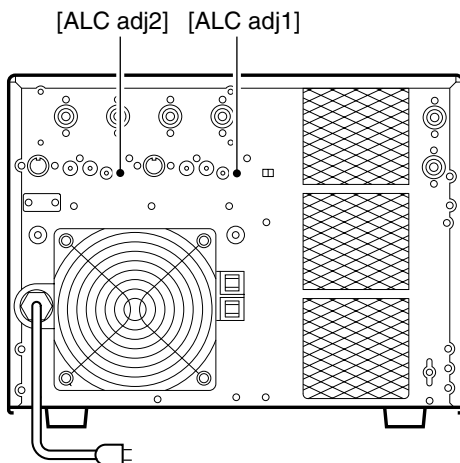

- ④ Push [POWER] to turn the linear amplifier power ON.
- ⑤ Push [UP] or [DOWN] to select an operating band except 50 MHz band.
 - Select a band which uses a well-matched 50 Ω antenna.

- ⑥ Push the transmit meter-2 switch one or more times to select the ALC level meter.
 - The [ALC] indicator lights.
- ⑦ Push [TUNER] to turn the antenna tuner ON.
 - The [TUNER] light lights.
- ⑧ While adjusting the 1st exciter's RF output power, transmit a 100 W output power of the selected band signal using CW or RTTY mode.
- ⑨ Adjust the [ALC adj1] pot to the ALC adjustment point as shown below.

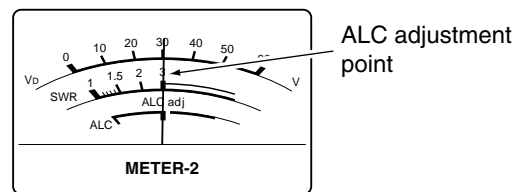

- ⑩ Check that the Po meter shows 1 kW output power.

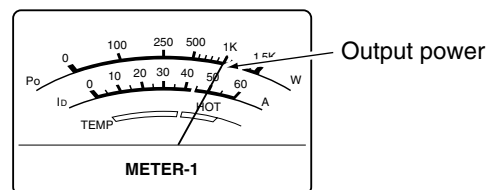

- ⑪ Adjust the [ALC adj2] pot in the same manner when a 2nd exciter is connected.

■ Programming the CI-V address

The IC-PW1/EURO uses CI-V frequency data for automatic selection of the operating band. Program the exciter's address to use this capability as follows:

For non-Icom exciters, the IC-PW1/EURO cannot be controlled using the CI-V function, so this setting is not necessary.

For transceivers which have multiple antenna connectors for specified bands (e.g. IC-726, IC-729, etc.), set the same as for 2 Icom exciters.

◆ Setting the Icom exciters

When connecting 2 or more CI-V devices:
DO NOT use the "AUTO" baud rate for CI-V devices. We recommend that all CI-V devices are set to 9600 bps.

- When using the same baud rate, the exciters' frequencies are synchronized.
- When using different baud rates (i.e. 4800 and 9600 bps, etc.), the exciters' frequencies are not synchronized.

- ① Confirm that the exciter's CI-V transceive function is ON.
 - Refer to the instruction manual for details.
- ② When connecting 2 exciters, connect the 1st and 2nd exciter to [INPUT1] and [INPUT2], respectively.
- ③ When connecting 2 Icom exciters, set [EXCITER] to the [1&2] position.
- ④ When connecting 2 or more CI-V devices, **DO NOT** set to "AUTO" baud rate.
 - Refer to the instruction manual for details.
 - When using the same baud rate, the exciters' frequencies are synchronized.
 - When using different baud rates (i.e. 4800 and 9600 bps, etc.), the exciters' frequencies are not synchronized. [INPUT 1] and [INPUT 2] selection is automatically selected using the exciter's baud rate.

- **DO NOT USE** CT-17 CI-V LEVEL CONVERTER to connect the remote control signal line for band control operation from an Icom exciter, or from the PC.
- Connect the supplied remote cable between the IC-PW1/EURO and Icom exciter directly.

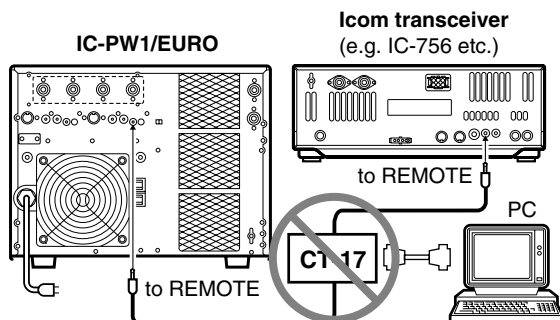

◆ When using 1 Icom exciter

- ① While pushing [INPUT], push [POWER] to enter the CI-V address programming mode.
 - [INPUT 1] blinks.

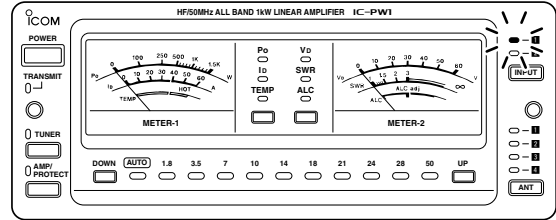

- ② Rotate the Icom exciter's tuning dial until the [INPUT 1] light continuously lights.
- ③ Push [POWER] to turn the IC-PW1/EURO power OFF and complete the setting.

◆ When using 2 Icom exciter's

- ① When using 2 Icom exciters, be sure that [EXCITER] is set to the [1&2] position.
- ② While pushing [INPUT], push [POWER] to enter the CI-V address programming mode.
 - [INPUT 1] blinks.

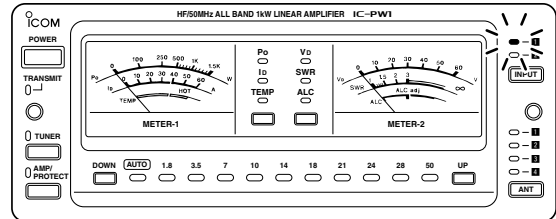

- ③ Push [DOWN].
 - The band indicators, [1.8]–[50], light continuously.
- ④ Rotate the 1st Icom exciter's tuning dial until the [INPUT 1] light continuously lights.
- ⑤ When 1 Icom exciter and 1 non-Icom exciter are connected, turn the power OFF to complete the setting. When 2 Icom exciters are connected, push [INPUT].
 - [INPUT 2] blinks when [INPUT] is pushed.
- ⑥ Rotate the 2nd Icom exciter's tuning dial until the [INPUT 2] light continuously lights.
- ⑦ Push [POWER] to complete the setting.

☞ Continue to the next page...

■ Programming the CI-V address (continued)

◇ Setting the IC-PW1/EURO's address

It is not necessary to change the IC-PW1/EURO's default CI-V address of 54H. However, if desired, the address can be changed using the internal address switch illustrated below.

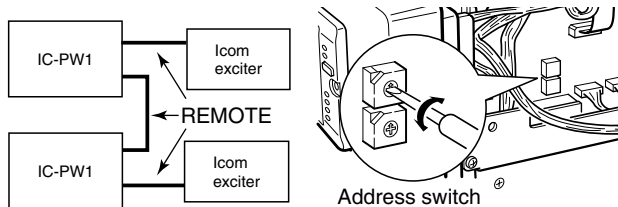

It is not necessary to change the IC-PW1/EURO's default CI-V address (default S3=5, S4=4). However, in the case when you will connect two (2) IC-PW1/EUROs like as above left1, please set a different address number using the internal address switch as illustrated as above right.

NOTE: Turn the power OFF when you are going to change the address setting, then programming the CI-V address again.

◇ Other NOTE:

• **IC-781;**
NEVER TURN THE POWER OFF of the IC-781 during the operation when you are using the IC-781 as one of the exciters, otherwise the CI-V control may be interrupted.

• **Baud rate;**
 Higher baud rate (e.g. 9600 bps) gives quick operation. When you select an extra Low baud rate (e.g. 300 bps), then the IC-PW1/EURO needs max. 15 sec. to start the operation.

• **"AUTO" baud rate;**
 When you want to use "AUTO" baud rate, turn the non-"AUTO" baud rate exciter ON first, then turn the "AUTO" baud rate exciter ON.

➔ Push [POWER] to turn the linear amplifier ON then turn the exciter's power ON.

■ Initial settings for CI-V remote control operation

Before setting the remote control operation, refer to the following operating procedure.

◇ When using one (1) Icom exciter with one (1) ANT line;

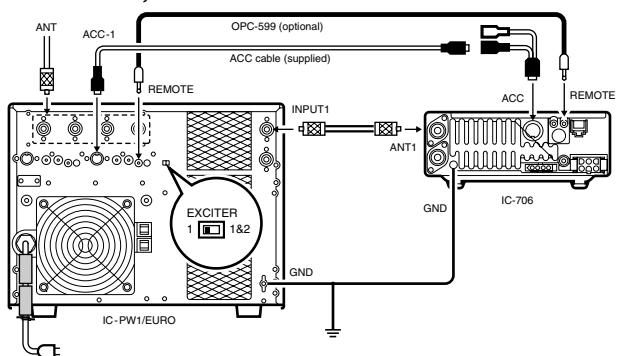

- ① Turn OFF both of the IC-PW1/EURO and exciter.
- ② Set [EXCITER] to [1] position.
- ③ While pushing and holding the [INPUT] switch on the IC-PW1/EURO controller, turn the exciter's power ON.
 - LED [INPUT 1] over the [INPUT] switch blinks.
- ④ Rotate the exciter's dial until the LED [INPUT 1] lights continuously.
- ⑤ Turn the exciter's power OFF to complete the setting.

◇ When using two (2) Icom exciters;

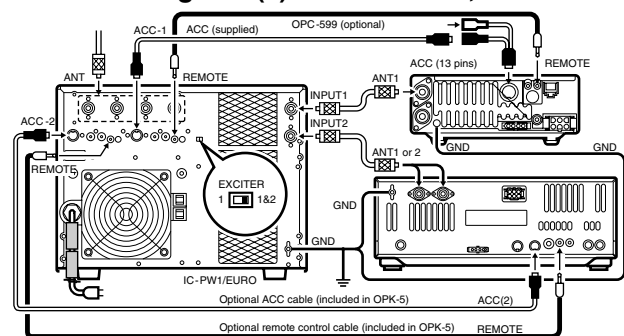

- ① Turn OFF both of the IC-PW1/EURO and exciters.
- ② Set [EXCITER] to [1&2] position.
- ③ Set the exciter's CI-V baud rate if required.
 - When selecting the different baud rate for each exciter, "CI-V data" setting may fail depending on the exciter. In such case, use the same baud rate for each exciter. Each exciter's frequencies may be synchronised.
 - When connecting the "AUTO" baud rate exciter and "Non-AUTO" baud rate exciter, the exciters' frequencies may not synchronize in some cases.
- ④ While pushing and holding the [INPUT] switch on the IC-PW1/EURO controller, turn the 1st exciter's power ON.
 - LED [INPUT 1] blinks.

☞ Continue to the next page

■ Initial settings for CI-V remote control operation (continued)

- ⑤ Push [DOWN] to turn the position memory function for the [INPUT] select switch ON.
 - The band indicators, [1.8]–[50], light continuously.
- ⑥ Rotate the 1st exciter's dial until the LED [INPUT 1] lights continuously.
- ⑦ Turn the 2nd exciter's power ON.
- ⑧ Push [INPUT].
 - LED [INPUT 2] blinks.
- ⑨ Rotate the 2nd exciter's dial until the LED [INPUT 2] lights continuously.
- ⑩ Turn both exciter's power OFF to complete the setting.

◆ When using one (1) Icom exciter with two (2) ANT lines (e.g. IC-756PRO etc.);

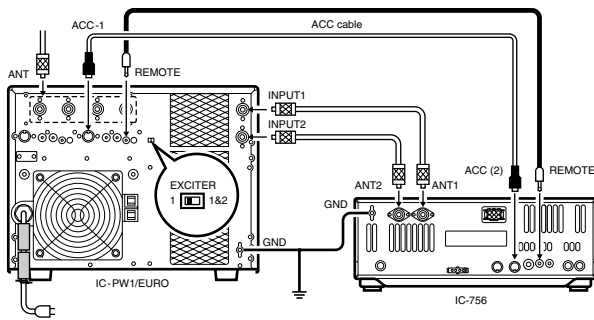

- ① Turn OFF both the IC-PW1/EURO and exciter.
- ② Set [EXCITER] to [1] position.
- ③ While pushing and holding the [INPUT] switch on the IC-PW1/EURO controller, turn the exciter's power ON.
 - LED [INPUT 1] blinks.
- ④ Rotate the exciter's dial until the LED [INPUT 1] lights continuously.
- ⑤ Push [INPUT].
 - LED [INPUT 2] blinks.
- ⑥ Rotate the exciter's dial until the LED [INPUT 2] lights continuously.
 - The band indicators, [1.8]–[50], turn OFF.
 - "AUTO" indicator lights continuously.
- ⑦ Turn the exciter's power OFF to complete the setting.

◆ When using one (1) Icom and one (1) non-Icom exciter;

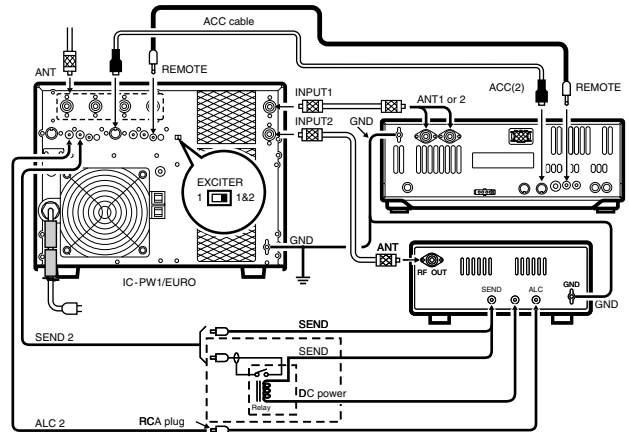

- ① Turn OFF both the IC-PW1/EURO and exciter.
- ② Set [EXCITER] to [1&2] position.
- ③ While pushing and holding the [INPUT] switch on the IC-PW1/EURO controller, turn the 1st exciter's power ON.
 - LED [INPUT 1] over the [INPUT] switch blinks.
- ④ Rotate the exciter's dial until the LED [INPUT 1] lights continuously.
- ⑤ Turn the exciter's power OFF to complete the setting.

◆ When using two (2) non-Icom exciters;

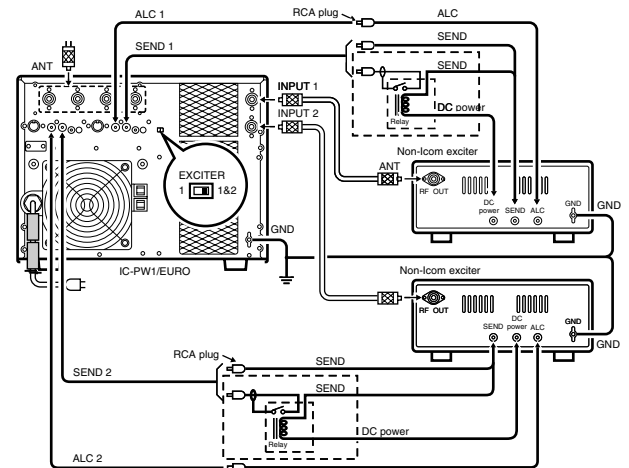

- ➔ Set [EXCITER] to [1&2] position, only.
- *No other setting is required.

■ Operation

CAUTION:

DO NOT operate the IC-PW1/EURO before adjusting the ALC levels properly with the [ALC adj1] and [ALC adj2] pots. (p. 11)

It takes 15 sec. for CI-V line initial settings when several CI-V devices (more than 5) are connected to a CI-V line.

For IC-781 users with other Icom CI-V transceivers:
Turn the IC-781 power ON before turning the IC-PW1/EURO and other transceiver power ON and keep the IC-781 power ON during operation.

- 1 Push [POWER] to turn the linear amplifier ON then turn the exciter's power ON.

[POWER]

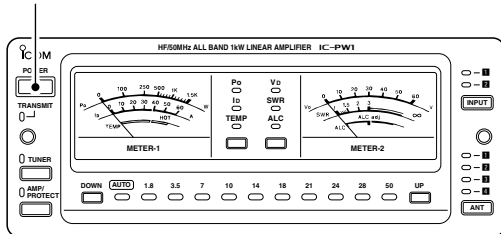

- 2 Select the input/output antenna with [INPUT] and [ANT].
- 3 Set the exciter to CW or RTTY mode with minimum output power.
- 4 Select the temperature and SWR meters with [METER-1] and [METER-2].
- The [TEMP] and [SWR] indicators light.

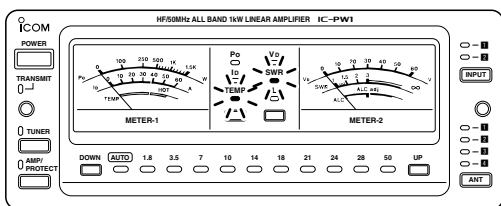

- 5 Push [TUNER] and [AMP/PROTECT] to turn the automatic antenna tuner and linear amplifier circuit ON.

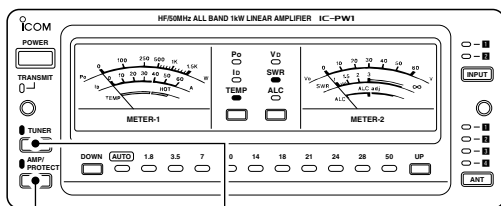

[AMP/PROTECT] [TUNER]

- 6 Push [UP]/[DOWN] to select [AUTO] for automatic band selection when a CI-V Icom exciter is used; or push [UP]/[DOWN] to select the desired band for manual band selection.
- 7 Use the exciter's antenna tuner to tune the line between the IC-PW1/EURO and exciter, if you have an antenna tuner connected to the exciter.
- 8 Transmit with the exciter and adjust the exciter's output power to 50 W with the RF output power control on the exciter.
- [TRANSMIT] indicator lights.
- See the exciter's instruction manual for transmitting.
- 9 The built-in antenna tuner automatically tunes the antenna.
- SWR reading on meter-2 should be less than 1.2:1.
- Push [TUNER] for 2 sec. to tune the antenna manually.
- The [TUNER] indicator blinks while tuning.
- The [TUNER] indicator lights while the tuner is activated.

NOTE: The band information is not updated while scanning. Turn the antenna tuner OFF and use the manual band selection while scanning.

During split operation:

When changing the frequency more than 100 kHz, the IC-PW1/EURO's antenna tuner presets the tuner to the new frequency. Use manual tuning during split operation.

- 10 When operating for long periods, select the temperature meter with [METER-1] to monitor the linear amplifier's temperature.
- If the temperature meter reading is in the red "HOT" zone, the exciter should be returned to receive, otherwise, the protection circuit may be activated and the linear amplifier may be turned OFF.

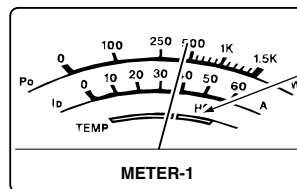

Temperature protection range

◆ Band memory

The IC-PW1/EURO stores ON/OFF settings for the antenna tuner and linear amplifier according to the operating band when at least 1 Icom exciter is connected to the [INPUT1] connector.

The set conditions may not be stored when the linear amplifier is turned OFF immediately after setting the antenna tuner and linear amplifier.

■ Antenna tuner operation

The built-in automatic antenna tuner can match the antenna feed line impedance to 50 Ω when the feed line impedance is within 16.7 to 150 Ω for HF bands (VSWR 3:1) or within 20 to 125 Ω for 50 MHz bands (VSWR 2.5:1).

Once the tuner matches an antenna, the tuning circuit condition is memorized as a preset point for each frequency range (100 kHz steps, 70 ranges). Therefore, when you change the frequency range, the tuning circuit is automatically preset to the memorized point.

This antenna tuner is also used when the linear amplifier is turned OFF.

➔ Push [TUNER] for 2 sec. to start manual antenna tuning.

- When the tuner cannot tune the antenna (SWR 1.5:1 or greater), the tuning circuit is bypassed automatically after 20 sec.

▨ While operating in the 50 MHz band, the antenna tuner does not start automatically. Push [TUNER] for 2 sec. to tune the antenna manually.

■ Protection circuit

This linear amplifier has various protection circuits.

◇ ALC circuit

The ALC (Automatic Level Control) circuit automatically limits RF output power by controlling the input level of the exciter. This prevents transmission of distorted signals when the input signal level exceeds the allowable level.

The ALC activates under the following conditions:

- Output power of the linear amplifier exceeds 1 kW
- Antenna SWR becomes 2:1 or more
- Output power of the exciter exceeds 100 W

◇ Cooling fans

- The power supply cooling fans activate when the linear amplifier is activated and while transmitting.
- The antenna tuner cooling fans activate when the antenna tuner is activated and while transmitting.
- All cooling fans activate when the heatsink temperature of the final FETs reaches 50 °C (122 °F) or more.

◇ Circuit breaker

If the circuit breaker activates or the linear amplifier stops functioning, try to find the source of the problem, then push the circuit breaker button to fill the white parts.

- Circuit breaker capacity: 20 A (U.S.A. version)
15 A (Europe version)

◇ Linear amplifier protection circuit

When a protection circuit is activated, a band indicator blinks to show a problem as described below.

➔ [AMP/PROTECT] lights red when a protection circuit is activated.

- Push [AMP/PROTECT] to cancel the protection circuit.

Item	Indication	Possible cause
1	[TEMP]	The heatsink temperature of the final FETs exceeds 100°C (212°F).
2	[AUTO]	Power level of the 4 PA units becomes unbalanced.
3	[ALC]	ALC control level exceeds the control range.
4	[V _b]	Output voltage of the internal power supply exceeds 55 V DC.
5	[I _b]	Current of the final FETs (I _b) exceeds 50 A.
6	Current band's indicator	Gain of the final FETs drops.
7	Selected and current band's indicator	When transmitting with different band selections between the linear amplifier and exciter.
8	[AMP/PROTECT]	The power supply has a malfunction.

■ Troubleshooting

The following chart is designed to help you correct problems which are not equipment malfunctions.

If you are unable to locate the cause of a problem or solve it through the use of this chart, contact your nearest Icom Dealer or Service Center.

PROBLEM	POSSIBLE CAUSE	SOLUTION	REF.
Power does not come on when the [POWER] switch is pushed.	<ul style="list-style-type: none"> • Cable connection is faulty. • The circuit breaker is turned OFF. 	<ul style="list-style-type: none"> • Check the connection and connection cable pins. • Check for the cause, then turn the circuit breaker ON. 	pgs. 7–10 p. 3
Sensitivity is low.	<ul style="list-style-type: none"> • The antenna is not connected properly. • The antenna for another band is selected. • The antenna is not properly tuned. 	<ul style="list-style-type: none"> • Reconnect the antenna connector. • Select an antenna suitable for the operating frequency. • Push [TUNER] for 2 sec. to manually tune the antenna. 	p. 6 p. 16 p. 17
Operating band does not change automatically.	<ul style="list-style-type: none"> • Cable connection is faulty. • CI-V setting is not properly programmed. 	<ul style="list-style-type: none"> • Check the connection and connection cable pins. • Set the CI-V address. 	pgs. 7–10 p. 13
Output power is too low.	<ul style="list-style-type: none"> • Reverse connection on the antenna input and output. • [ALC adj] is not adjusted properly. • The linear amplifier circuit is turned OFF. • The antenna for another band is selected. • The antenna is not properly tuned. • The protection circuit activates and a band indicator blinks. 	<ul style="list-style-type: none"> • Connect properly. • Set [ALC adj] properly. • Push [AMP/PROTECT] to turn the linear amplifier ON. (The indicator lights green.) • Select an antenna suitable for the operating frequency. • Push [TUNER] for 2 sec. to manually tune the antenna. • Stop the exciter's transmission, then push [AMP/PROTECT] to deactivate the protection circuit. 	pgs. 7–10 p. 12 p. 16 p. 16 p. 16 p. 17
Protection circuit activates during short periods of operation.	<ul style="list-style-type: none"> • Antenna SWR is more than 3:1. • The antenna tuner is turned OFF. • The linear amplifier is located in an area with bad air circulation. • [ALC adj] is not adjusted properly. 	<ul style="list-style-type: none"> • Check the antenna SWR. Adjust the antenna, if necessary. • Push [TUNER] to turn the antenna tuner ON. • Select a location with good air circulation. • Adjust [ALC adj] to the correct position. 	p. 6 p. 17 — p. 12

■ General

- Frequency coverage: 1.800– 1.999 MHz
3.500– 3.999 MHz
7.000– 7.300 MHz
10.100–10.150 MHz
14.000–14.350 MHz
18.068–18.168 MHz
21.000–21.450 MHz
24.890–24.990 MHz*¹
28.000–29.700 MHz*¹
50.000–54.000 MHz
*¹ The U.S.A. version can only be used the antenna tuner on the 24–28 MHz bands.
- Antenna connector :
Input PL-239×2 (50 Ω)
Output PL-239×4 (50 Ω)
- Usable temperature : –10°C to 40°C (14°F to 104°F) range
- Power supply requirement:
non-Europe versions 100–120 V AC or
200–240 V AC (±10 %)
Europe version 230 V AC (±10 %)
- Dimensions (W × H × D):
Linear amplifier 350 × 265 × 375 mm
13²⁵/₃₂ × 10⁷/₁₆ × 14³/₄ in
Remote controller 205 × 71 × 68.3 mm
8¹/₁₆ × 2²⁵/₃₂ × 2¹¹/₁₆ in
(Projections not included)
- Weight : Approx. 25 kg (55 lb)
(incl. remote controller)
- CI-V connector : 2-conductor 3.5(d) mm (1/8")

■ Transmitter

- Output power :

MODE	INPUT AC VOLTAGE	
	200–240 V AC	100–120 V AC
CW, RTTY	1 kW	500 W
SSB	1 kW PEP	500 W PEP

- Driving power : 100 W max.
- Spurious emissions : –60 dB (HF bands)
–70 dB (50 MHz band)
- SEND connector : Phono (RCA)
- ALC connector : Phono (RCA)

■ Antenna tuner

- Matching impedance range:
HF bands*² 16.7 to 150 Ω unbalanced
(Less than VSWR 3:1)
50 MHz band 20 to 125 Ω unbalanced
(Less than VSWR 2.5:1)
*²The U.S.A. version can only be tuned within 1.80–1.95 MHz of the 1.8 MHz band.
- Minimum operating input power:
60 W
- Tuning accuracy : VSWR 1.5:1 or less
- Insertion loss : Less than 1.0 dB
(after tuning)



We Icom Inc. Japan
1-1-32, Kamiminami, Hirano-ku
Osaka 547-0003, Japan

Declare on our sole responsibility that this equipment complies with the essential requirements of the Radio and Telecommunications Terminal Equipment Directive, 1999/5/EC, and that any applicable Essential Test Suite measurements have been performed.

Kind of equipment: HF+50 MHz 1 kW LINEAR AMPLIFIER

Type-designation: IC-PWIEURO+ OPC-853

Version (where applicable):

This compliance is based on conformity according to Annex III of the directive 1999/5/EC using the following harmonised standards:

- i) Article 3.1a EN 60950-1 (2001)
EN60065:2002 +A1:2006 (Power supply)
EN60065:1998 (Power supply)
- ii) Article 3.1b EN 301489-1 and EN 301489-15
- iii) Article 3.2 EN 301 783-2

DECLARATION OF CONFORMITY



Düsseldorf 1st Dec. 2006
Place and date of issue

Icom (Europe) GmbH
Himmelgeisterstraße 100
D-40225 Düsseldorf
Authorized representative name

H. Ikegami
General Manager

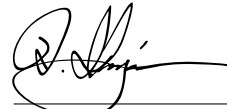

Signature Icom Inc.

INSTALLATION NOTES

For amateur base station installations it is recommended that the forwards clearance in front of the antenna array is calculated relative to the EIRP (Effective Isotropic Radiated Power). The clearance height below the antenna array can be determined in most cases from the RF power at the antenna input terminals.

As different exposure limits have been recommended for different frequencies, a relative table shows a guideline for installation considerations.

Below 30 MHz, the recommended limits are specified in terms of V/m or A/m fields as they are likely to fall within the near-field region. Similarly, the antennas may be physically short in terms of electrical length and that the installation will require some antenna matching device which can create local, high intensity magnetic fields. Analysis of such MF installations is best considered in association with published guidance notes such as the FCC OET Bulletin 65 Edition 97-01 and its annexes relative to amateur transmitter installations. The EC recommended limits are almost identical to the FCC specified 'uncontrolled' limits and tables exist that show pre-calculated safe distances for different antenna types for different frequency bands. Further information can be found at <http://www.arrl.org/>.

• Typical amateur radio installation

Exposure distance assumes that the predominant radiation pattern is forwards and that radiation vertically downwards is at unity gain (sidelobe suppression is equal to main lobe gain). This is true of almost every gain antenna today. Exposed persons are assumed to be beneath the antenna array and have a typical height of 1.8 m.

The figures assume the worst case emission of constant carrier.

For the bands 10 MHz and higher the following power density limits have been recommended:

10–144 MHz	2 W/sq m
------------	----------

EIRP clearance heights by frequency band

1 Watts	2.1 m
10 Watts	2.8 m
25 Watts	3.4 m
100 Watts	5 m
1000 Watts	12 m

Forward clearance, EIRP by frequency band

100 Watts	2 m
1000 Watts	6.5 m
10,000 Watts	20 m
100,000 Watts	65 m

In all cases any possible risk depends on the transmitter being activated for long periods. (actual recommendation limits are specified as an average during 6 minutes) Normally the transmitter is not active for long periods of time. Some radio licenses will require that a timer circuit automatically cuts the transmitter after 1–2 minutes etc.

Similarly some types of emission, i.e., SSB, CW, AM etc. have a lower 'average' output power and the assessed risk is even lower.



Versions of the IC-PW1EURO which display the "CE" symbol on the serial number seal, comply with the essential requirements of the European Radio and Telecommunication Terminal Directive 1999/5/EC.



This warning symbol indicates that this equipment operates in non-harmonised frequency bands and/or may be subject to licensing conditions in the country of use. Be sure to check that you have the correct version of this radio or the correct programming of this radio, to comply with national licensing requirement.

NOTE: To meet European R&TTE regulations, the OPC-853 AC cable with EMC filter must be connected to the IC-PW1EURO.

Count on us!

